

**Model**

MP20

Product Description

Planetary Mixer, 20 litre, Heavy Duty

Product Code

5MP20

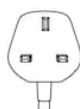
**Standard Features**

- Heavy duty 20ltr, bench mounted, gear driven, planetary mixer
- Particularly suitable for bakeries, hotels, restaurants, canteens etc
- Easy to operate
- Planetary mixing action ensures perfect results
- High torque motor allows mixing of stiffer doughs and larger batches
- 3 fixed speeds: 140, 260 and 473 rpm
- Easy speed-shifting
- Interlocking bowl guard and bowl lift
- Stainless steel safety guard with ingredient chute and automatic shut-off when guard is opened at any speed
- Industry standard #12 attachment hub
- Thermal overload protection (NVR device)
- Emergency stop button
- Long lasting lubricant providing abrasion resistant transmission
- Transmission gears are made of heat treated, hardened steel
- All metal and die-cast aluminium body
- Non-slip rubber feet
- Quiet operation

Standard Accessories / Attachments

- 1 x Whisk
- 1 x Beater
- 1 x Dough Hook
- 1 x 20 litre Stainless steel bowl

Warranty

Covered by Metcalfe 3-year warranty (1st year parts and labour, 2nd & 3rd years parts only) and full after sales service

Optional Accessories / Attachments

Item	Product Code	Item	Product Code	Item	Product Code
Bowl	MP11012-12-001	Stand	5MP21	10ltr reduction bowl	MP11012-12-005
Beater	MP11012-12-002	Trolley	5MP22	10ltr reduction beater	MP11012-12-006
Dough Hook	MP11012-12-003A	Veg Prep Attachment	MPVS12A	10ltr reduction dough hook	MP11012-12-007
Whisk	MP11012-12-004	Meat Mincer Attachment	MPG12SH	10ltr reduction whisk	MP11012-12-008

Drawing

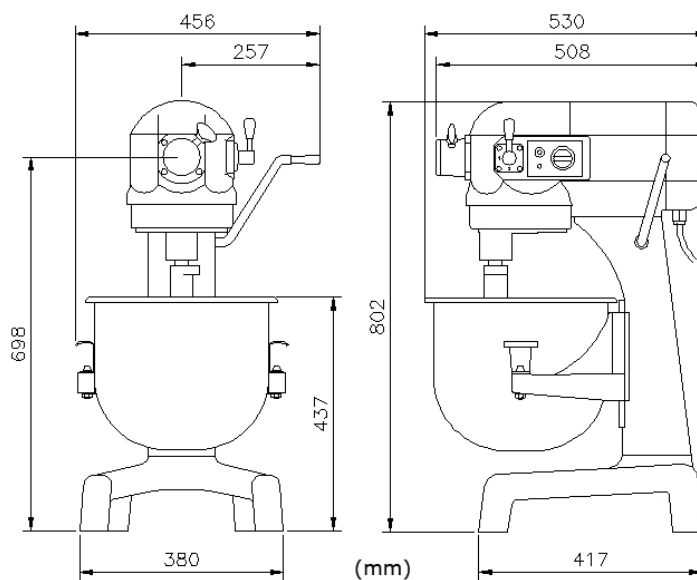

Specifications

Model	Capacity (ltr)	Phase (Ø)	Motor (Volt)	Frequency (Hz)	Power (kW) / (hp)	Speed (rpm)
MP20	20	1	220-240	50	0.375 / 0.5	140 / 260 / 473

Dimensions | Shipping Information

Model	Overall Dimensions D x W x H (mm)	Net Weight (kg)	Packed Dimensions D x W x H (mm)	Packed Weight (kg)	Volume (m3)
MP20	530 x 456 x 802	98	620 x 520 x 1000	110	0.32

We reserve the right to alter the specification and technical details for this item at any time without prior notice. 05/2021

Metcalfe Catering Equipment Ltd

Haygarth Park
Blaenau Ffestiniog
Gwynedd, LL41 3PF

